

NINGBO ZHAFIR PLASTICS MACHINERY MANUFACTURING CO., LTD.

No. 98 Guanhai Road, Chunxiao, Beilun, Ningbo, China 315800

Tel. +86-574-86182986

Fax. +86-574-86182977

E-Mail: contact@mail.zhafir.cn

www.zhafir.cn



ZERES III

SPECIFICATION | INTERNATIONAL

4,500 – 13,800 kN

ZF 20211027-IV



TECHNICAL DATA ZE4500 III

		ZE4500 III												
CLAMPING UNIT	Clamping force	kN	4500											
	Mold opening stroke	mm	800											
	Mold height min.	mm	350											
	Mold height max.	mm	810											
	Max. daylight	mm	1610											
	Dist. between tie bars (H×V)	mm	910×910											
	Min. mold dimension	mm	590×590											
	Ejector stroke	mm	180											
	Ejector force	kN	98											
	Size of mold platen (H×V)	mm	1300×1300											
INJECTION UNIT	Screw diameter	mm	A	B	C	A	B	C	A	B	C	A	B	C
		L/D	21.8	20	18.5	21.6	20	18.6	21.5	20	17.5	21.3	20	17.8
		Injection volume (theoretical) ¹	cm ³	617	735	862	791	929	1077	1068	1239	1618	1634	1859
	Injection weight (PS) ²	g	562	668	785	720	845	980	972	1127	1472	1487	1692	2141
		MPa	214	180	153	210	180	155	210	180	138	205	180	142
	Holding pressure ³	bar	2140	1800	1530	2100	1800	1550	2100	1800	1380	2050	1800	1420
		MPa	190	160	136	187	160	138	190	162	124	185	162	128
	Screw speed	rpm		300			250			210			185	
		g/s	54	64	71	57	68	72	56	65	80	62	80	100
	Plasticizing rate (HDPE) ⁵	g/s	-	-	-	-	-	-	80	95	120	93	115	150
Nozzle contact force	kN		85			85			85			85		
Heating power	kW		29.7			34.3			37.6			45		
OTHERS	INJECTION UNIT		1400			1700			2250			3350		
	Injection speed	mm/s	160			160			160			160		
	Injection rate (PS)	g/s	332	395	463	395	463	537	463	537	702	617	702	889
	INJECTION UNIT		1400h			1700h			2250h			-		
	Injection speed	mm/s	250			250			250			-		
	Injection rate (PS)	g/s	518	617	724	617	724	840	723	839	1097	-	-	-
	Connection power	kW/A	1400:53/90 1400h:56/94			1700:56/93 1700h:59/98			2250:73/122 2250h:106/177			85/143		
	Pressure	MPa	17.5			17.5			17.5			17.5		
	Flow	l/min	132			132			132			132		
	Oil tank	l	280			280			280			280		
Hopper capacity	l	50			50			50			100			
Machine dimension	m	8.9×2.3×2.6			8.9×2.3×2.6			8.9×2.3×2.6			8.9×2.3×2.6			
Machine weight	t	26.20			26.30			28.40			28.63			

NOTE: ¹ Shot volume is the theoretical value which equals to cross section area of screw cylinder or barrel plunger × screw stroke.
² Shot weight (PS) is the theoretical value of shot volume melt density of PS. It is not a measured value.
³ Injection & holding pressure are theoretical values of machine output, not the actual resin pressure.
⁴ Plasticizing capacity(GPPS):GB standard, with application of GPPS plasticizing capacity of 3-zone screws.
⁵ Plasticizing capacity(HDPE):Euromap 19, with application of HDPE plasticizing capacity of barrier screws.

This parameter table is based on machine standard configuration;
 We reserve the right to make changes as a result of further technical advances.

MACHINE DIMENSIONS

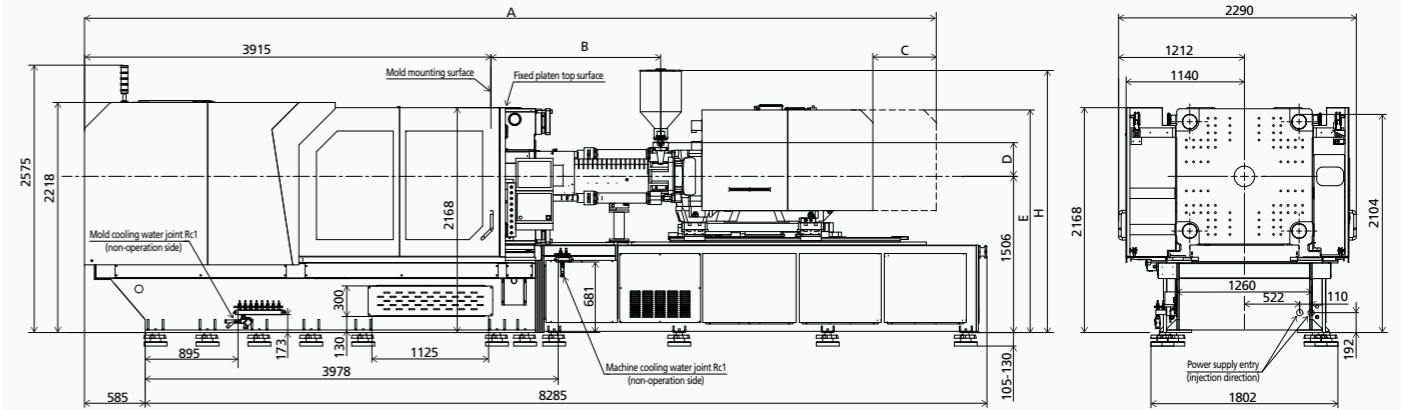

	A	B	C	D	E	F	G	H	I	J	K	L	M	N
1400h,1400	8169	1382	560	251	2211	4×M10 L20	115	2360	149	Ø80	115	184	Ø3	SR10
1700h,1700	8367	1547	560	250	2211	4×M10 L20	115	2360	148	Ø80	115	217	Ø3	SR10
2250h,2250	8214	1636	610	327	2146	4×M10 L20	115	2436	225	Ø85	115	70	Ø4	SR15
3350	8481	1841	610	346	2146	4×M12 L25	170	2867	225	Ø100	170	128	Ø4	SR15

PLATEN DIMENSIONS

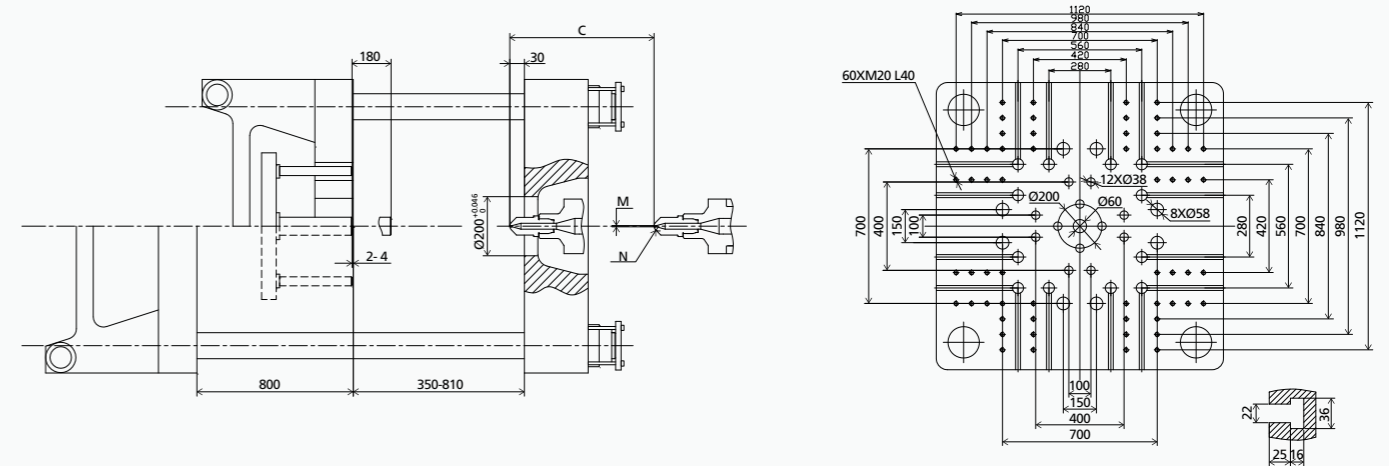

OTHERS DIMENSIONS

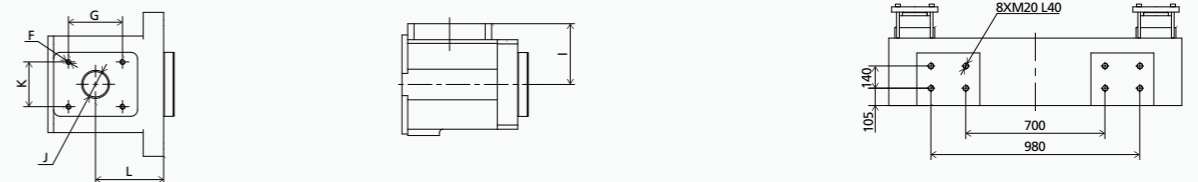

TECHNICAL DATA ZE5500 III

		ZE5500 III												
CLAMPING UNIT	Clamping force	kN	5500											
	Mold opening stroke	mm	900											
	Mold height min.	mm	400											
	Mold height max.	mm	880											
	Max. daylight	mm	1780											
	Dist. between tie bars (H×V)	mm	970×970											
	Min. mold dimension	mm	630×630											
	Ejector stroke	mm	180											
	Ejector force	kN	154											
	Size of mold platen (H×V)	mm	1400×1400											
INJECTION UNIT	Screw diameter	mm	A	B	C	A	B	C	A	B	C	A	B	C
		55	60	65	60	65	70	65	70	80	75	80	90	
		L/D	21.8	20	18.5	21.6	20	18.6	21.5	20	17.5	21.3	20	17.8
	Injection volume (theoretical) ¹	cm ³	617	735	862	791	929	1077	1068	1239	1618	1634	1859	2353
		g	562	668	785	720	845	980	972	1127	1472	1487	1692	2141
	Injection pressure ³	MPa	214	180	153	210	180	155	210	180	138	205	180	142
		bar	2140	1800	1530	2100	1800	1550	2100	1800	1380	2050	1800	1420
	Holding pressure ³	MPa	190	160	136	187	160	138	190	162	124	185	162	128
		bar	1900	1600	1360	1870	1600	1380	1900	1620	1240	1850	1620	1280
	Screw speed	rpm	300			250			210			185		
Plasticizing rate (GPPS) ⁴	g/s	54	64	71	57	68	72	56	65	80	62	80	100	
Plasticizing rate (HDPE) ⁵	g/s	-	-	-	-	-	-	80	95	120	93	115	150	
Nozzle contact force	kN	85			85			85			85			
Heating power	kW	29.7			34.3			37.6			45			
OTHERS	INJECTION UNIT		1400			1700			2250			3350		
	Injection speed	mm/s	160			160			160			160		
	Injection rate (PS)	g/s	332	395	463	395	463	537	463	537	702	617	702	889
	INJECTION UNIT		1400h			1700h			2250h			-		
	Injection speed	mm/s	250			250			250			-		
	Injection rate (PS)	g/s	518	617	724	617	724	840	723	839	1097	-	-	-
	Connection power	kW/A	1400:53/90 1400h:56/94			1700:56/93 1700h:59/98			2250:73/122 2250h:106/177			85/143		
	Pressure	MPa	17.5			17.5			17.5			17.5		
	Flow	l/min	180			180			180			180		
	Oil tank	l	326			326			326			326		
Hopper capacity	l	50			50			50			100			
Machine dimension	m	9.4×2.5×2.6			9.4×2.5×2.6			9.4×2.5×2.6			9.4×2.5×2.6			
Machine weight	t	30.60			30.82			32.26			32.55			

NOTE: ¹ Shot volume is the theoretical value which equals to cross section area of screw cylinder or barrel plunger × screw stroke.
² Shot weight (PS) is the theoretical value of shot volume melt density of PS. It is not a measured value.
³ Injection & holding pressure are theoretical values of machine output, not the actual resin pressure.
⁴ Plasticizing capacity(GPPS):GB standard, with application of GPPS plasticizing capacity of 3-zone screws.
⁵ Plasticizing capacity(HDPE):Euromap 19, with application of HDPE plasticizing capacity of barrier screws.

This parameter table is based on machine standard configuration;
 We reserve the right to make changes as a result of further technical advances.

MACHINE DIMENSIONS

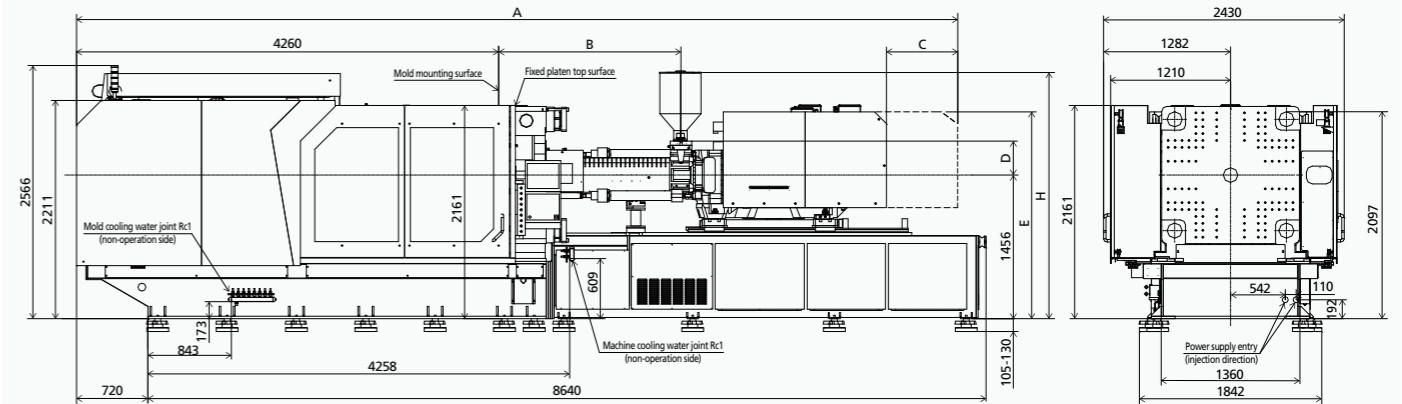

	A	B	C	D	E	F	G	H	I	J	K	L	M	N
1400h,1400	8564	1382	610	251	2161	4×M10 L20	115	2310	149	Ø80	115	184	Ø3	SR10
1700h,1700	8762	1547	610	250	2161	4×M10 L20	115	2310	148	Ø80	115	217	Ø3	SR10
2250h,2250	8559	1636	610	327	2096	4×M10 L20	115	2386	225	Ø85	115	70	Ø4	SR15
3350	8936	1841	720	346	2096	4×M12 L25	170	2817	225	Ø100	170	128	Ø4	SR15

PLATEN DIMENSIONS

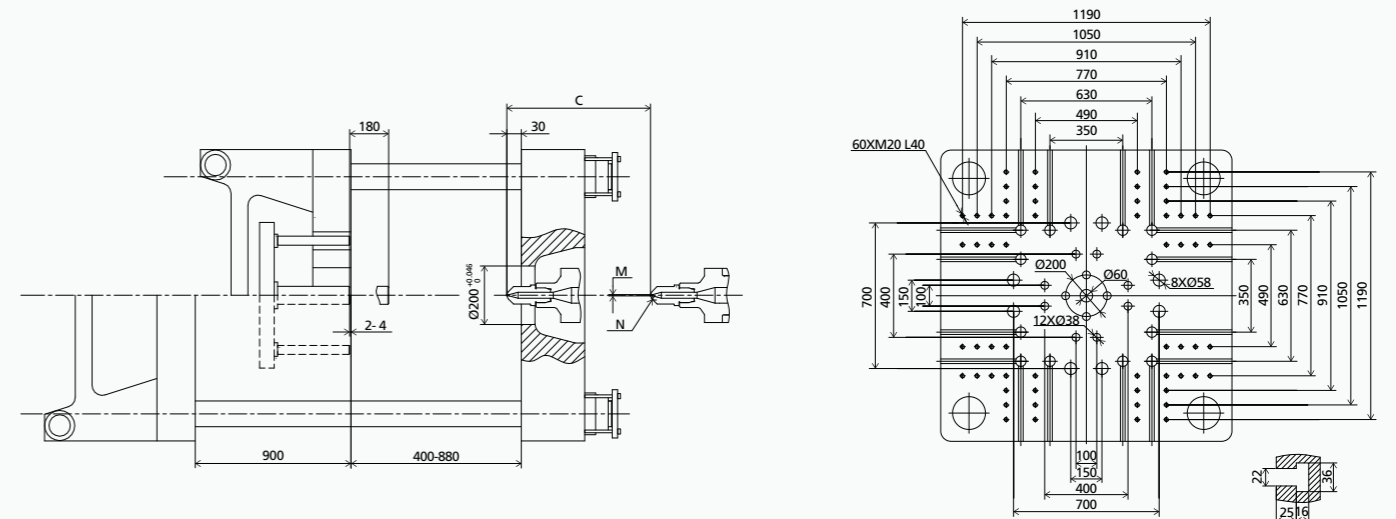

OTHERS DIMENSIONS

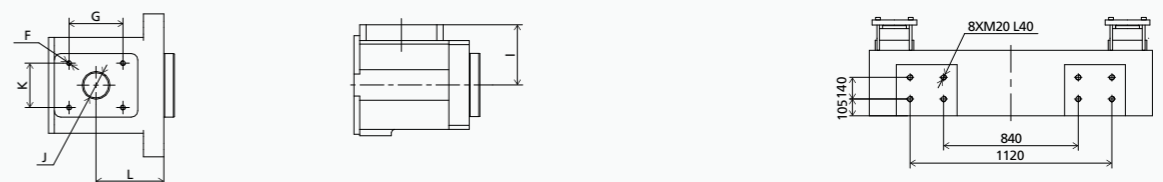

TECHNICAL DATA ZE6500 III

ZE6500 III

		ZE6500 III											
		A	B	C	A	B	C	A	B	C	A	B	C
Clamping force	kN	6500											
Mold opening stroke	mm	1000											
Mold height min.	mm	420											
Mold height max.	mm	1000											
Max. daylight	mm	2000											
Dist. between tie bars (H×V)	mm	1080×1080											
Min. mold dimension	mm	700×700											
Ejector stroke	mm	200											
Ejector force	kN	196											
Size of mold platen (H×V)	mm	1550×1550											
Screw diameter	mm	60	65	70	65	70	80	75	80	90	80	90	100
Screw L/D ratio	L/D	21.6	20	18.6	21.5	20	17.5	21.3	20	17.8	24.8	22	19.8
Injection volume (theoretical) ¹	cm ³	791	929	1077	1068	1239	1618	1634	1859	2353	2261	2862	3534
Injection weight (PS) ²	g	720	845	980	972	1127	1472	1487	1692	2141	2058	2605	3216
Injection pressure ³	MPa	210	180	155	210	180	138	205	180	142	227	180	145
	bar	2100	1800	1550	2100	1800	1380	2050	1800	1420	2270	1800	1450
Holding pressure ³	MPa	187	160	138	190	162	124	185	162	128	204	162	131
	bar	1870	1600	1380	1900	1620	1240	1850	1620	1280	2040	1620	1310
Screw speed	rpm	250			210			185			160		
Plasticizing rate (GPPS) ⁴	g/s	57	68	72	56	65	80	62	80	100	78	98	120
Plasticizing rate (HDPE) ⁵	g/s	-	-	-	80	95	120	93	115	150	115	146	180
Nozzle contact force	kN	85			85			85			85		
Heating power	kW	34.3			37.6			45			54.3		
INJECTION UNIT		1700			2250			3350			5200		
Injection speed	mm/s	160			160			160			160		
Injection rate (PS)	g/s	395	463	537	463	537	702	617	702	889	702	889	1097
INJECTION UNIT		1700h			2250h			-			-		
Injection speed	mm/s	250			250			-			-		
Injection rate (PS)	g/s	617	724	840	723	839	1097	-	-	-	-	-	-
Connection power	kW/A	1700:56/93 1700h:59/98			2250:73/122 2250h:106/177			85/143			113/190		
Pressure	MPa	17.5			17.5			17.5			17.5		
Flow	l/min	252			252			252			252		
Oil tank	l	450			450			450			450		
Hopper capacity	l	50			50			100			100		
Machine dimension	m	10.2×2.6×2.8			10.2×2.6×2.8			10.2×2.6×2.8			10.2×2.6×2.8		
Machine weight	t	39.56			38.44			38.84			41.22		

NOTE: ¹ Shot volume is the theoretical value which equals to cross section area of screw cylinder or barrel plunger × screw stroke.
² Shot weight (PS) is the theoretical value of shot volume melt density of PS. It is not a measured value.
³ Injection & holding pressure are theoretical values of machine output, not the actual resin pressure.
⁴ Plasticizing capacity(GPPS):GB standard, with application of GPPS plasticizing capacity of 3-zone screws.
⁵ Plasticizing capacity(HDPE):Euromap 19, with application of HDPE plasticizing capacity of barrier screws.

This parameter table is based on machine standard configuration;
 We reserve the right to make changes as a result of further technical advances.

MACHINE DIMENSIONS

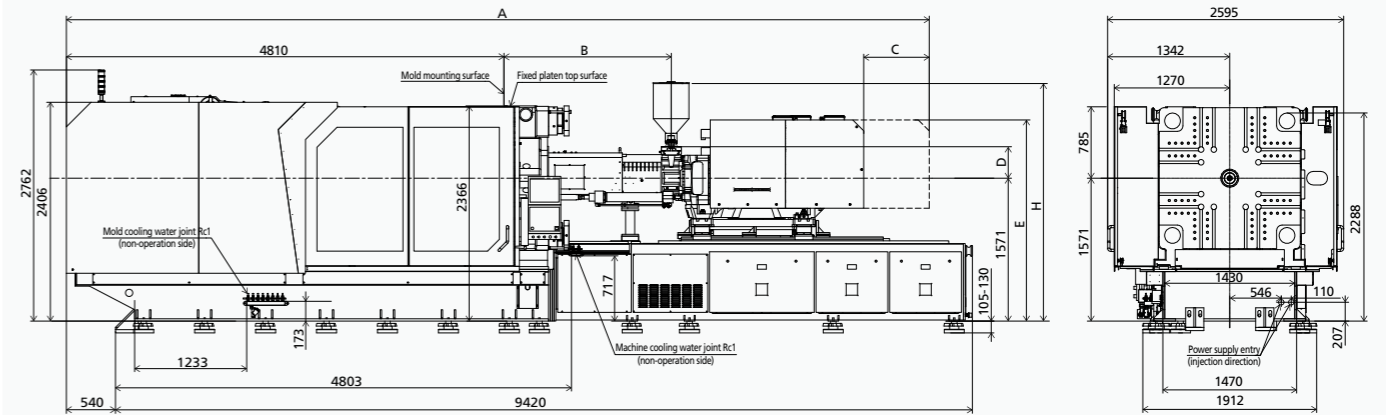

	A	B	C	D	E	F	G	H	I	J	K	L	M	N
1700h,1700	9312	1547	610	250	2276	4XM10 L20	115	2424	148	Ø80	115	217	Ø3	SR10
2250h,2250	9109	1636	610	327	2211	4XM10 L20	115	2501	225	Ø85	115	70	Ø4	SR15
3350	9485	1841	720	346	2211	4XM12 L25	170	2932	225	Ø100	170	128	Ø4	SR15
5200	10117	2276	720	401	2363	4XM12 L20	170	2987	220	Ø100	170	105	Ø4	SR15

PLATEN DIMENSIONS

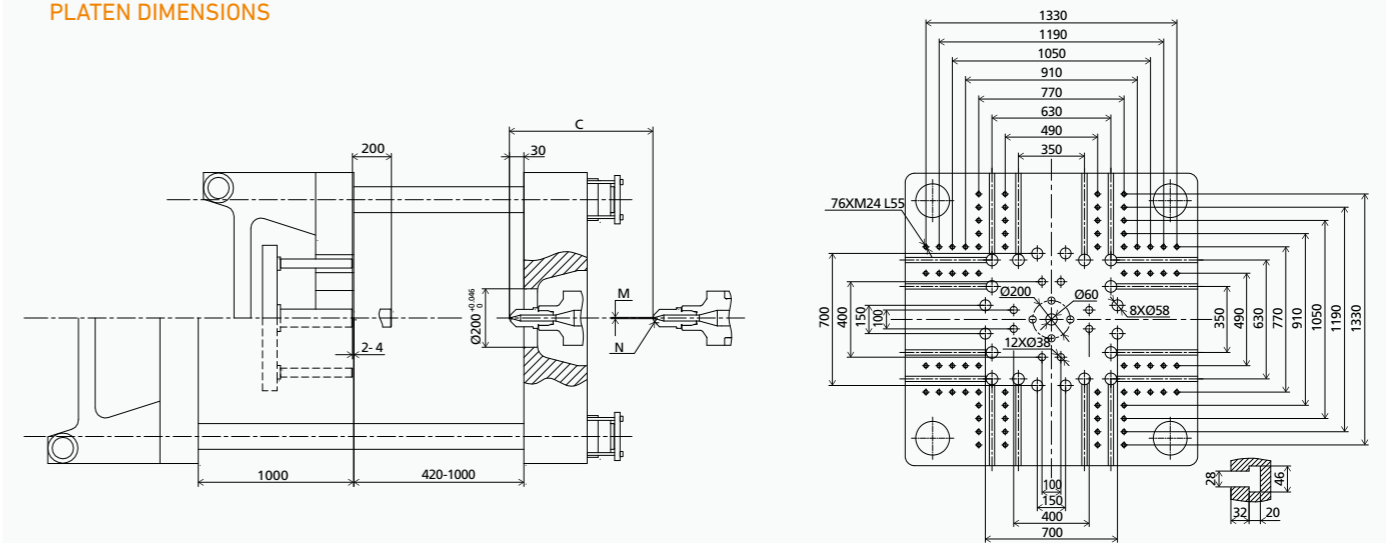

OTHERS DIMENSIONS

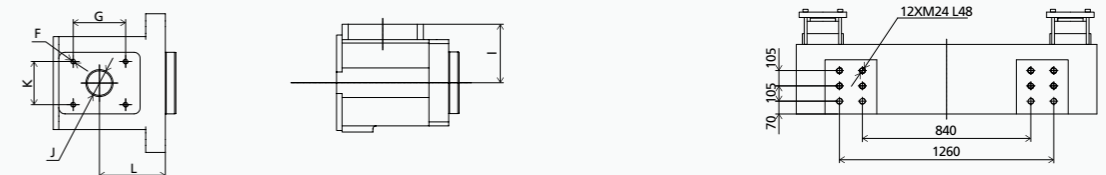

TECHNICAL DATA ZE8000 III

		ZE8000 III												
CLAMPING UNIT	Clamping force	kN	8000											
	Mold opening stroke	mm	1000											
	Mold height min.	mm	420											
	Mold height max.	mm	1000											
	Max. daylight	mm	2000											
	Dist. between tie bars (H×V)	mm	1080×1080											
	Min. mold dimension	mm	700×700											
	Ejector stroke	mm	200											
	Ejector force	kN	196											
	Size of mold platen (H×V)	mm	1550×1550											
INJECTION UNIT	Screw diameter	mm	A	B	C	A	B	C	A	B	C	A	B	C
		L/D	21.6	20	18.6	21.5	20	17.5	21.3	20	17.8	24.8	22	19.8
		Injection volume (theoretical) ¹	cm ³	791	929	1077	1068	1239	1618	1634	1859	2353	2261	2862
	Injection weight (PS) ²	g	720	845	980	972	1127	1472	1487	1692	2141	2058	2605	3216
		MPa	210	180	155	210	180	138	205	180	142	227	180	145
	Holding pressure ³	bar	2100	1800	1550	2100	1800	1380	2050	1800	1420	2270	1800	1450
		MPa	187	160	138	190	162	124	185	162	128	204	162	131
	Screw speed	rpm		250			210			185			160	
		g/s	57	68	72	56	65	80	62	80	100	78	98	120
	Plasticizing rate (HDPE) ⁵	g/s	-	-	-	80	95	120	93	115	150	115	146	180
kN			85			85			85			85		
Heating power	kW		34.3			37.6			45			54.3		
OTHERS	INJECTION UNIT		1700			2250			3350			5200		
	Injection speed	mm/s	160			160			160			160		
	Injection rate (PS)	g/s	395	463	537	463	537	702	617	702	889	702	889	1097
	INJECTION UNIT		1700h			2250h			-			-		
	Injection speed	mm/s	250			250			-			-		
	Injection rate (PS)	g/s	617	724	840	723	839	1097	-	-	-	-	-	-
	Connection power	kW/A	1700:56/93 1700h:59/98			2250:73/122 2250h:106/177			85/143			113/190		
	Pressure	MPa	17.5			17.5			17.5			17.5		
	Flow	l/min	252			252			252			252		
	Oil tank	l	450			450			450			450		
Hopper capacity	l	50			50			100			100			
Machine dimension	m	10.2×2.6×2.8			10.2×2.6×2.8			10.2×2.6×2.8			10.2×2.6×2.8			
Machine weight	t	37.5			38.4			38.8			43.52			

NOTE: ¹ Shot volume is the theoretical value which equals to cross section area of screw cylinder or barrel plunger × screw stroke.
² Shot weight (PS) is the theoretical value of shot volume melt density of PS. It is not a measured value.
³ Injection & holding pressure are theoretical values of machine output, not the actual resin pressure.
⁴ Plasticizing capacity(GPPS):GB standard, with application of GPPS plasticizing capacity of 3-zone screws.
⁵ Plasticizing capacity(HDPE):Euromap 19, with application of HDPE plasticizing capacity of barrier screws.

This parameter table is based on machine standard configuration;
 We reserve the right to make changes as a result of further technical advances.

MACHINE DIMENSIONS

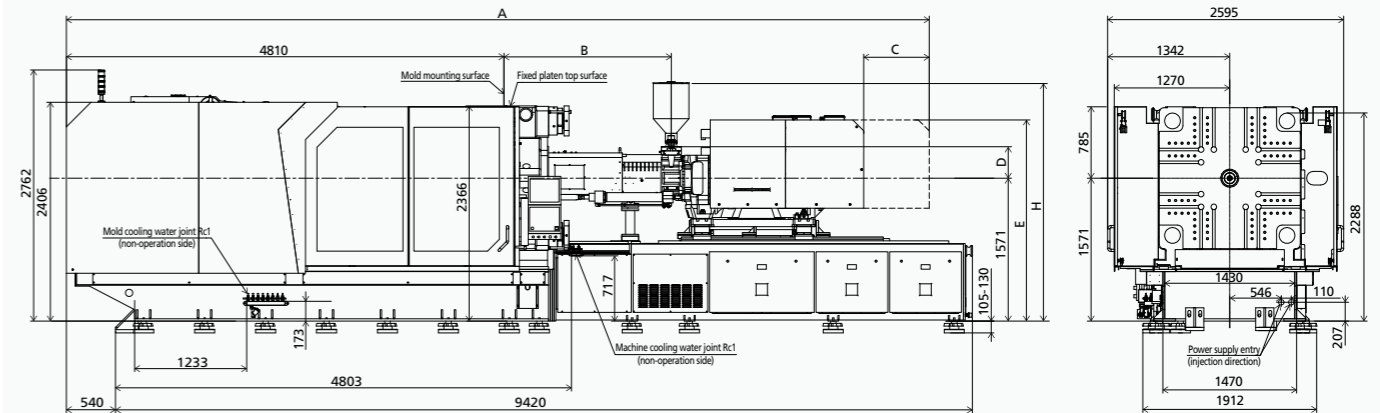

	A	B	C	D	E	F	G	H	I	J	K	L	M	N
1700h,1700	9312	1547	610	250	2276	4XM10 L20	115	2424	148	Ø80	115	217	Ø3	SR10
2250h,2250	9109	1636	610	327	2211	4XM10 L20	115	2501	225	Ø85	115	70	Ø4	SR15
3350	9485	1841	720	346	2211	4XM12 L25	170	2932	225	Ø100	170	128	Ø4	SR15
5200	10117	2276	720	401	2363	4XM12 L20	170	2987	220	Ø100	170	105	Ø4	SR15

PLATEN DIMENSIONS

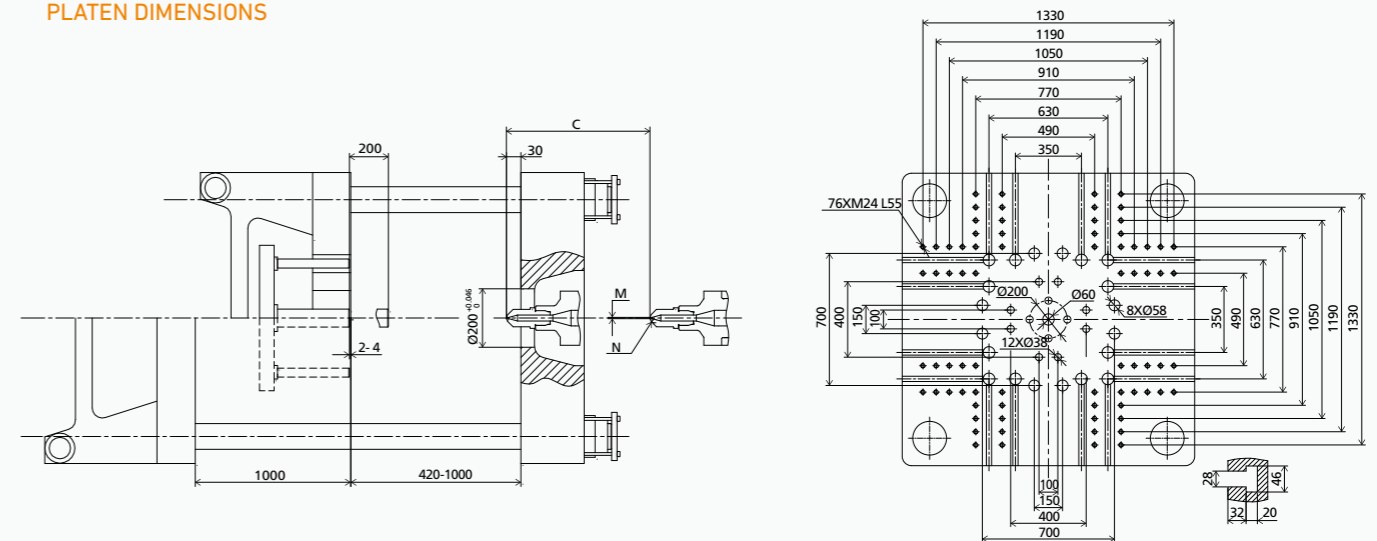

OTHERS DIMENSIONS

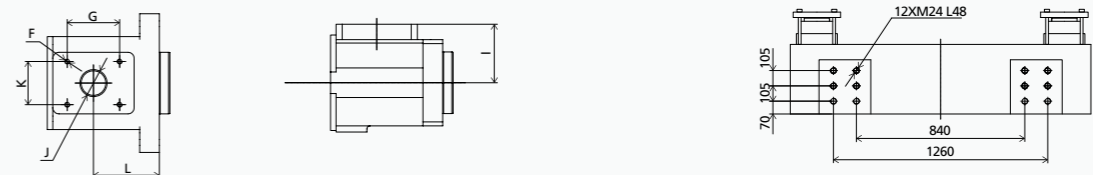

TECHNICAL DATA ZE9000 III

		ZE9000 III												
CLAMPING UNIT	Clamping force	kN	9000											
	Mold opening stroke	mm	1200											
	Mold height min.	mm	450											
	Mold height max.	mm	1100											
	Max. daylight	mm	2300											
	Dist. between tie bars (H×V)	mm	1160×1160											
	Min. mold dimension	mm	770×770											
	Ejector stroke	mm	200											
	Ejector force	kN	230											
	Size of mold platen (H×V)	mm	1700×1700											
INJECTION UNIT	Screw diameter	mm	A	B	C	A	B	C	A	B	C	A	B	C
		L/D	21.5	20	17.5	21.3	20	17.8	24.8	22	19.8	24.4	22	20
		cm ³	1068	1239	1618	1634	1859	2353	2261	2862	3534	2989	3691	4466
	Injection weight (PS) ²	g	972	1127	1472	1487	1692	2141	2058	2605	3216	2720	3359	4064
		MPa	210	180	138	205	180	142	227	180	145	234	190	157
	Holding pressure ³	bar	2100	1800	1380	2050	1800	1420	2270	1800	1450	2340	1900	1570
		MPa	190	162	124	185	162	128	204	162	131	200	162	134
	Screw speed	rpm		210			185			160			150	
		g/s	56	65	80	62	80	100	78	98	120	100	120	145
	Plasticizing rate (HDPE) ⁵	g/s	80	95	120	93	115	150	115	146	180	147	180	214
Nozzle contact force	kN		85			85			85			107.8		
Heating power	kW		37.6			45			54.3			75.6		
OTHERS	INJECTION UNIT		2250			3350			5200			7000		
	Injection speed	mm/s	160			160			160			150		
	Injection rate (PS)	g/s	463	537	702	617	702	889	702	889	1097	833	1029	1245
	INJECTION UNIT		2250h			-			-			-		
	Injection speed	mm/s	250			-			-			-		
	Injection rate (PS)	g/s	723	839	1097	-	-	-	-	-	-	-	-	-
	Connection power	kW/A	2250:73/122 2250h:106/177			85/143			113/190			124/207		
	Pressure	MPa	17.5			17.5			17.5			17.5		
	Flow	l/min	310			310			310			310		
	Oil tank	l	530			530			530			530		
Hopper capacity	l	50			100			100			100			
Machine dimension	m	11.8×3.0×2.8			11.8×3.0×2.8			11.8×3.0×2.8			11.8×3.0×2.8			
Machine weight	t	65			66			68.5			71			

NOTE: ¹ Shot volume is the theoretical value which equals to cross section area of screw cylinder or barrel plunger × screw stroke.
² Shot weight (PS) is the theoretical value of shot volume melt density of PS. It is not a measured value.
³ Injection & holding pressure are theoretical values of machine output, not the actual resin pressure.
⁴ Plasticizing capacity(GPPS):GB standard, with application of GPPS plasticizing capacity of 3-zone screws.
⁵ Plasticizing capacity(HDPE):Euromap 19, with application of HDPE plasticizing capacity of barrier screws.

This parameter table is based on machine standard configuration;
 We reserve the right to make changes as a result of further technical advances.

MACHINE DIMENSIONS

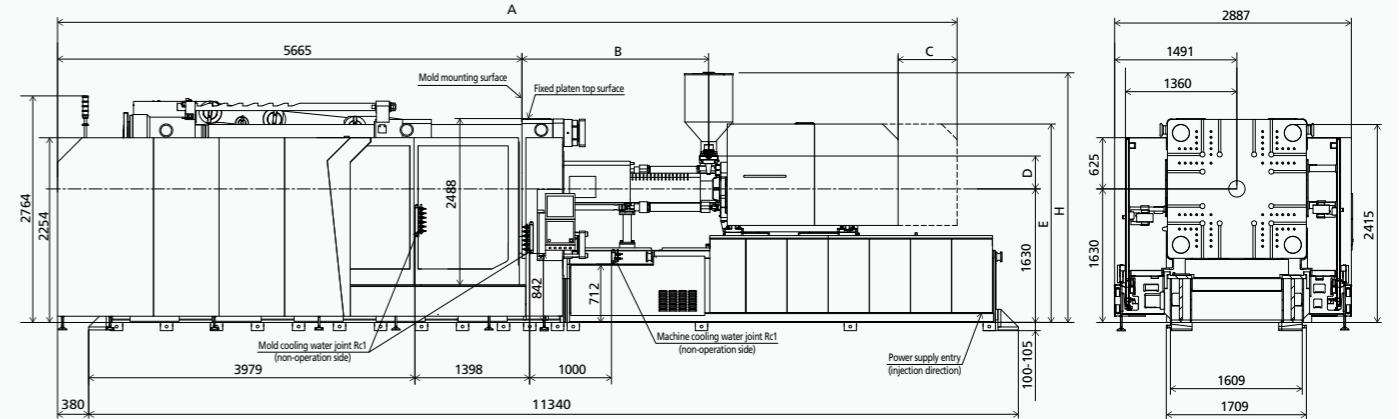

	A	B	C	D	E	F	G	H	I	J	K	L	M	N
2250h,2250	9965	1635	610	327	2270	4XM10 L20	115	2560	225	Ø85	115	70	Ø4	SR15
3350	10370	1841	720	346	2270	4XM12 L25	170	2991	225	Ø100	170	128	Ø4	SR15
5200	10973	2276	720	401	2422	4XM12 L20	170	3046	220	Ø100	170	105	Ø4	SR15
7000	11641	2524	720	233	2422	4XM12 L20	170	2878	232	Ø122	170	115	Ø6	SR20

PLATEN DIMENSIONS

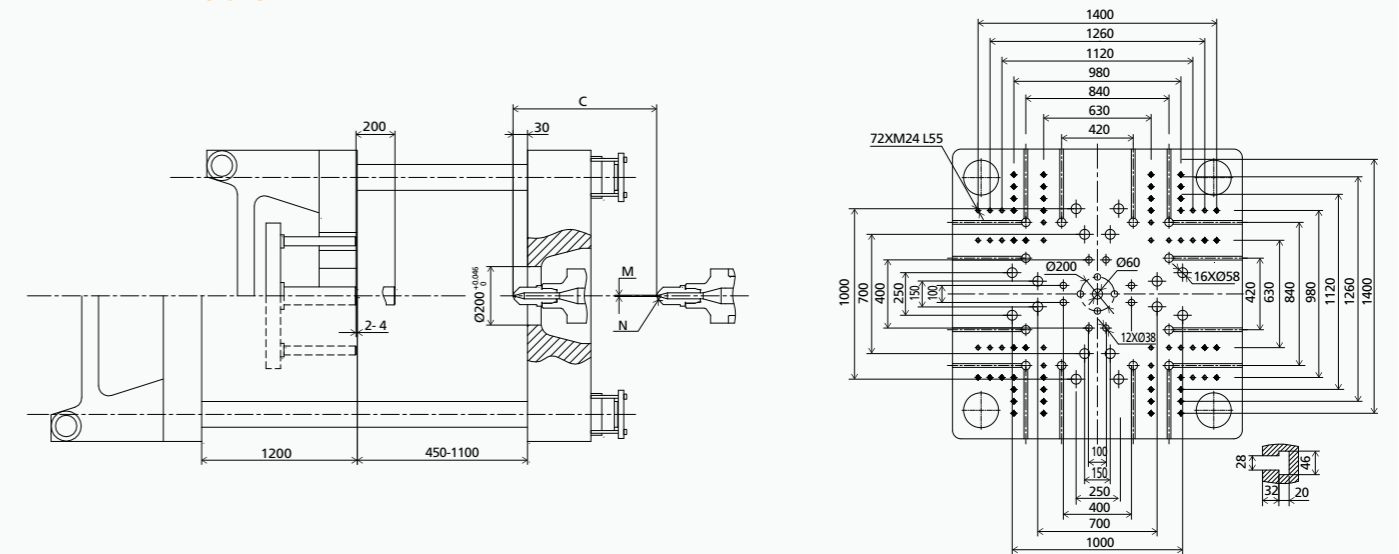

OTHERS DIMENSIONS



TECHNICAL DATA ZE10800 III

ZE10800 III

CLAMPING UNIT		ZE10800 III											
Clamping force	kN	10800											
Mold opening stroke	mm	1300											
Mold height min.	mm	500											
Mold height max.	mm	1200											
Max. daylight	mm	2500											
Dist. between tie bars (H×V)	mm	1320×1320											
Min. mold dimension	mm	870×870											
Ejector stroke	mm	200											
Ejector force	kN	230											
Size of mold platen (H×V)	mm	1885×1885											
		A	B	C	A	B	C	A	B	C	A	B	C
Screw diameter	mm	75	80	90	80	90	100	90	100	110	100	110	120
Screw L/D ratio	L/D	21.3	20	17.8	24.8	22	19.8	24.4	22	20	24.2	22	20.2
Injection volume (theoretical) ¹	cm ³	1634	1859	2353	2261	2862	3534	2989	3691	4466	4005	4846	5767
Injection weight (PS) ²	g	1487	1692	2141	2058	2605	3216	2720	3359	4064	3644	4410	5248
Injection pressure ³	MPa	205	180	142	227	180	145	234	190	157	230	190	160
	bar	2050	1800	1420	2270	1800	1450	2340	1900	1570	2300	1900	1600
Holding pressure ³	MPa	185	162	128	204	162	131	200	162	134	202	167	141
	bar	1850	1620	1280	2040	1620	1310	2000	1620	1340	2020	1670	1410
Screw speed	rpm	185			160			150			150		
Plasticizing rate (GPPS) ⁴	g/s	62	80	100	78	98	120	100	120	145	130	156	180
Plasticizing rate (HDPE) ⁵	g/s	93	115	150	115	146	180	147	180	214	190	228	260
Nozzle contact force	kN	85			85			107.8			107.8		
Heating power	kW	45			54.3			75.6			82.8		
INJECTION UNIT		3350			5200			7000			9200		
Injection speed	mm/s	160			160			150			150		
Injection rate (PS)	g/s	617	702	889	702	889	1097	833	1029	1245	1029	1245	1482
INJECTION UNIT		-			-			-			-		
Injection speed	mm/s	-			-			-			-		
Injection rate (PS)	g/s	-			-			-			-		
Connection power	kW/A	85/143			113/190			124/207			143/239		
Pressure	MPa	17.5			17.5			17.5			17.5		
Flow	l/min	310			310			310			310		
Oil tank	l	530			530			530			530		
Hopper capacity	l	100			100			100			200		
Machine dimension	m	12.6×3.2×2.9			12.6×3.2×2.9			12.6×3.2×2.9			12.7×3.2×2.9		
Machine weight	t	72			75			77			78		

CLAMPING UNIT

INJECTION UNIT

OTHERS

NOTE: ¹ Shot volume is the theoretical value which equals to cross section area of screw cylinder or barrel plunger × screw stroke.
² Shot weight (PS) is the theoretical value of shot volume melt density of PS. It is not a measured value.
³ Injection & holding pressure are theoretical values of machine output, not the actual resin pressure.
⁴ Plasticizing capacity(GPPS): GB standard, with application of GPPS plasticizing capacity of 3-zone screws.
⁵ Plasticizing capacity(HDPE): Euromap 19, with application of HDPE plasticizing capacity of barrier screws.

This parameter table is based on machine standard configuration;
 We reserve the right to make changes as a result of further technical advances.

MACHINE DIMENSIONS

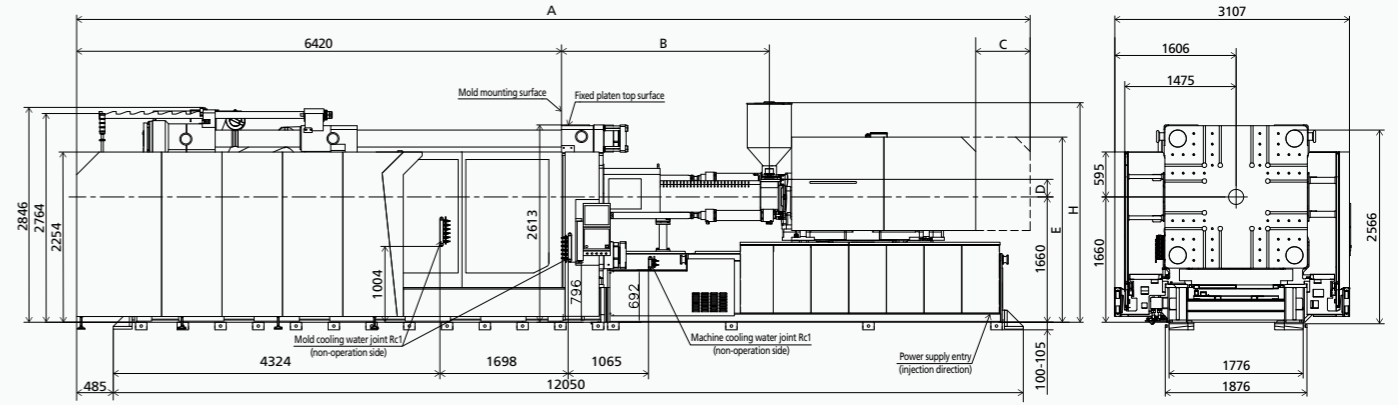

	A	B	C	D	E	F	G	H	I	J	K	L	M	N
	3350	11095	1841	720	346	2300	4XM12 L25	170	3021	225	Ø100	170	128	Ø4 SR15
	5200	11728	2276	720	401	2452	4XM12 L20	170	3076	220	Ø100	170	105	Ø4 SR15
	7000	12396	2524	720	233	2452	4XM12 L20	170	2908	232	Ø122	170	115	Ø6 SR20
	9200	12625	2753	720	233	2452	4XM12 L20	170	2908	232	Ø122	170	115	Ø6 SR20

PLATEN DIMENSIONS

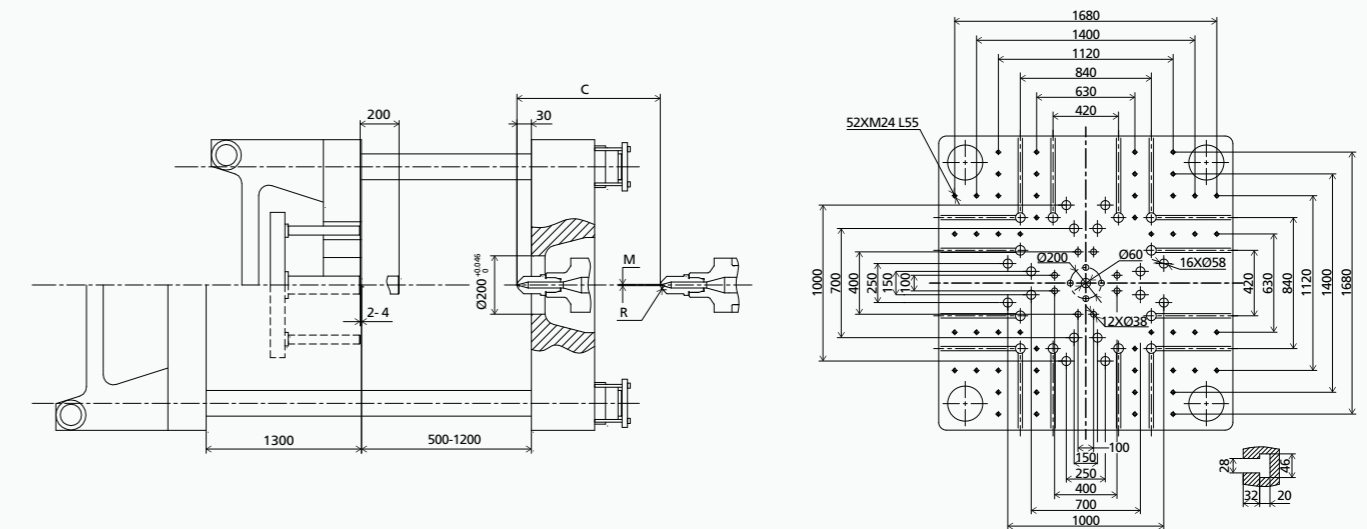

OTHERS DIMENSIONS

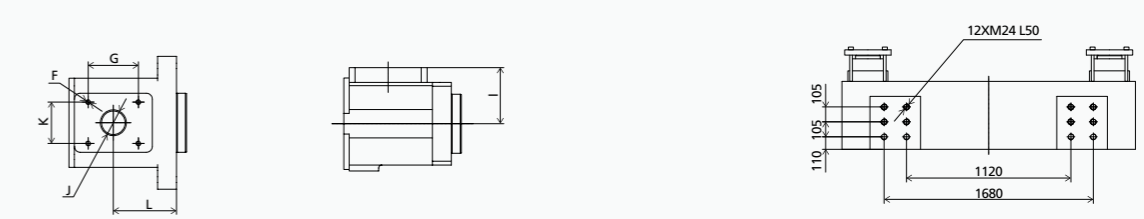

TECHNICAL DATA ZE13800 III

ZE13800 III

		ZE13800 III									
CLAMPING UNIT	Clamping force	kN	13800								
	Mold opening stroke	mm	1500								
	Mold height min.	mm	650								
	Mold height max.	mm	1300								
	Max. daylight	mm	2800								
	Dist. between tie bars (H×V)	mm	1550×1450								
	Min. mold dimension	mm	1030×970								
	Ejector stroke	mm	250								
	Ejector force	kN	300								
	Size of mold platen (H×V)	mm	2250×2180								
INJECTION UNIT			A	B	C	A	B	C	A	B	C
	Screw diameter	mm	80	90	100	90	100	110	100	110	120
	Screw L/D ratio	L/D	24.8	22	19.8	24.4	22	20	24.2	22	20.2
	Injection volume (theoretical) ¹	cm ³	2261	2862	3534	2989	3691	4466	4005	4846	5767
	Injection weight (PS) ²	g	2058	2605	3216	2720	3359	4064	3644	4410	5248
	Injection pressure ³	MPa	227	180	145	234	190	157	230	190	160
		bar	2270	1800	1450	2340	1900	1570	2300	1900	1600
	Holding pressure ³	MPa	204	162	131	200	162	134	202	167	141
		bar	2040	1620	1310	2000	1620	1340	2020	1670	1410
	Screw speed	rpm	160			150			150		
Plasticizing rate (GPPS) ⁴	g/s	78	98	120	100	120	145	130	156	180	
Plasticizing rate (HDPE) ⁵	g/s	115	146	180	147	180	214	190	228	260	
Nozzle contact force	kN	85			107.8			107.8			
Heating power	kW	54.3			75.6			82.8			
OTHERS	INJECTION UNIT		5200			7000			9200		
	Injection speed	mm/s	160			150			150		
	Injection rate (PS)	g/s	702	889	1097	833	1029	1245	1029	1245	1482
	INJECTION UNIT		-			-			-		
	Injection speed	mm/s	-			-			-		
	Injection rate (PS)	g/s	-			-			-		
	Connection power	kW/A	113/190			124/207			143/239		
	Pressure	MPa	17.5			17.5			17.5		
	Flow	l/min	350			350			350		
	Oil tank	l	530			530			530		
Hopper capacity	l	100			100			200			
Machine dimension	m	13.3×3.6×3.2			13.3×3.6×3.2			13.3×3.6×3.2			
Machine weight	t	116			120			120			

NOTE: ¹ Shot volume is the theoretical value which equals to cross section area of screw cylinder or barrel plunger × screw stroke.
² Shot weight (PS) is the theoretical value of shot volume melt density of PS. It is not a measured value.
³ Injection & holding pressure are theoretical values of machine output, not the actual resin pressure.
⁴ Plasticizing capacity(GPPS):GB standard, with application of GPPS plasticizing capacity of 3-zone screws.
⁵ Plasticizing capacity(HDPE):Euromap 19, with application of HDPE plasticizing capacity of barrier screws.

This parameter table is based on machine standard configuration;
 We reserve the right to make changes as a result of further technical advances.

MACHINE DIMENSIONS

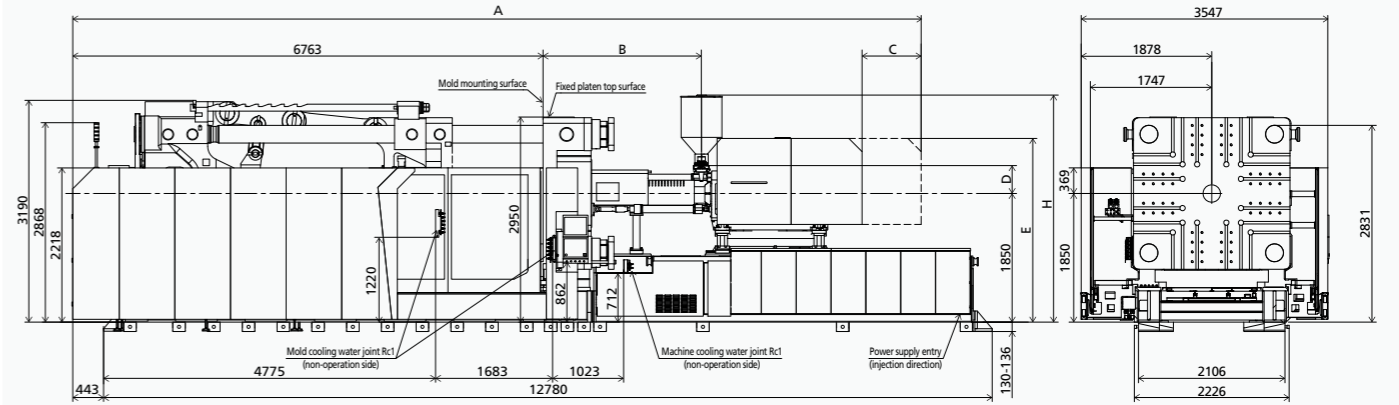

	A	B	C	D	E	F	G	H	I	J	K	L	M	N
5200	12201	2276	850	401	2642	4XM12 L20	170	3266	220	Ø100	170	105	Ø4	SR15
7000	12869	2524	850	233	2642	4XM12 L20	170	3098	232	Ø122	170	115	Ø6	SR20
9200	13098	2753	850	233	2642	4XM12 L20	170	3098	232	Ø122	170	115	Ø6	SR20

PLATEN DIMENSIONS

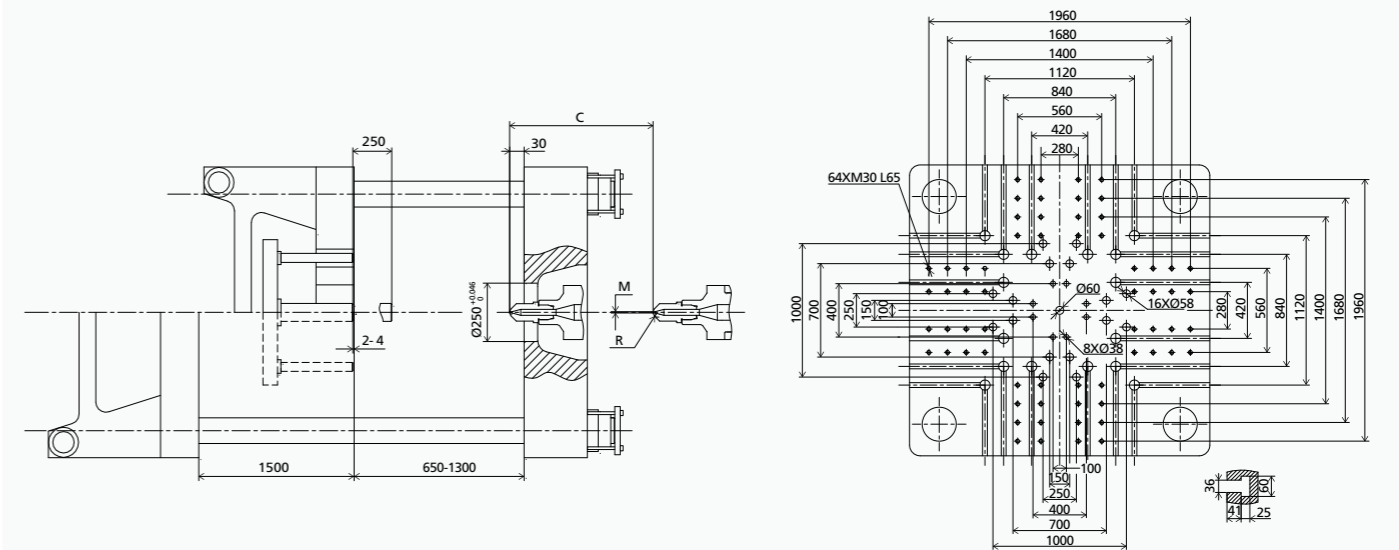

OTHERS DIMENSIONS

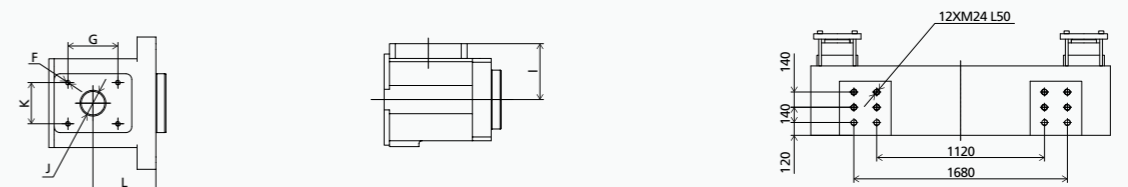

PLATEN LAYOUT ZE4500 III

EUROPEAN VERSION FIXED PLATEN

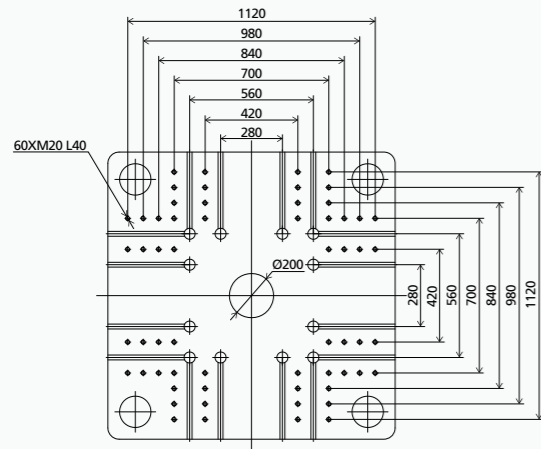

MOVABLE PLATEN

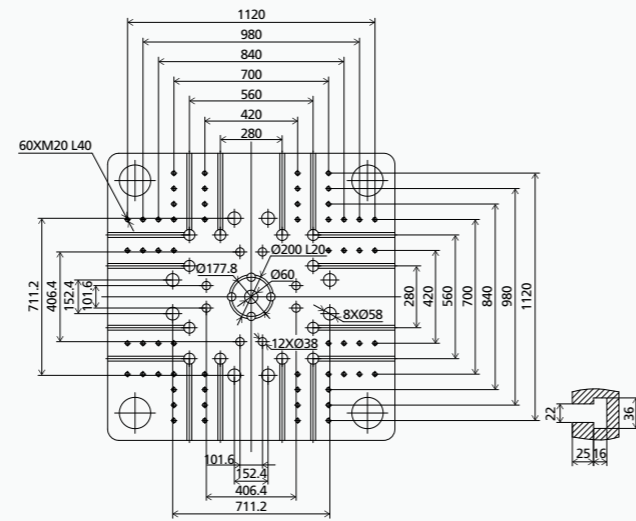

EUROPEAN VERSION FIXED PLATEN

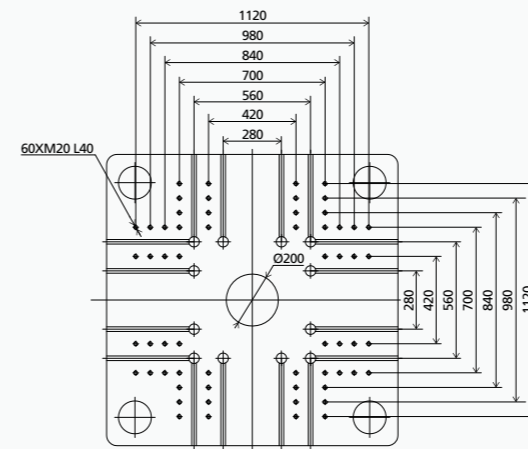

MOVABLE PLATEN

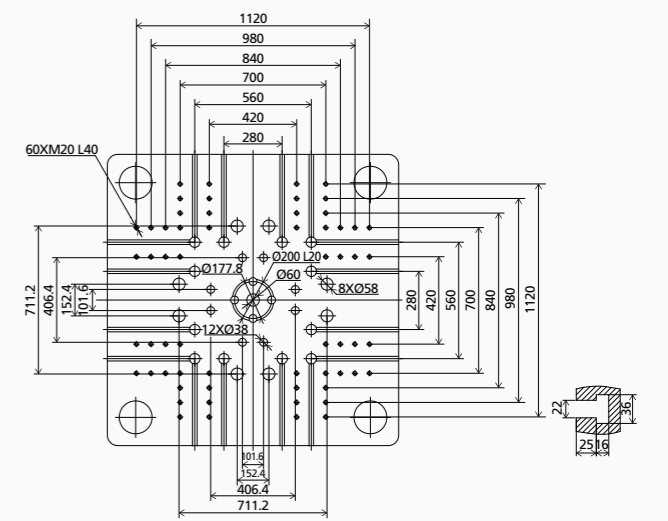

AMERICAN VERSION FIXED PLATEN

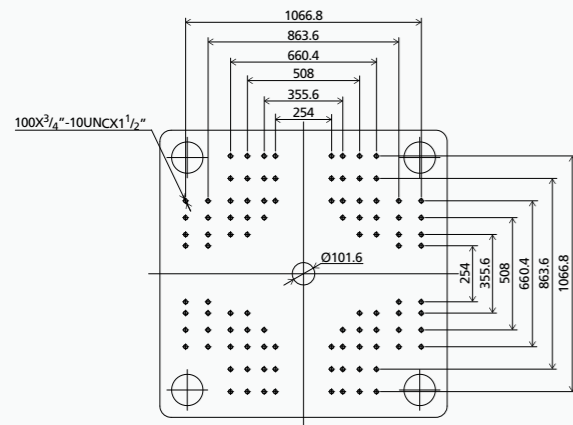

MOVABLE PLATEN

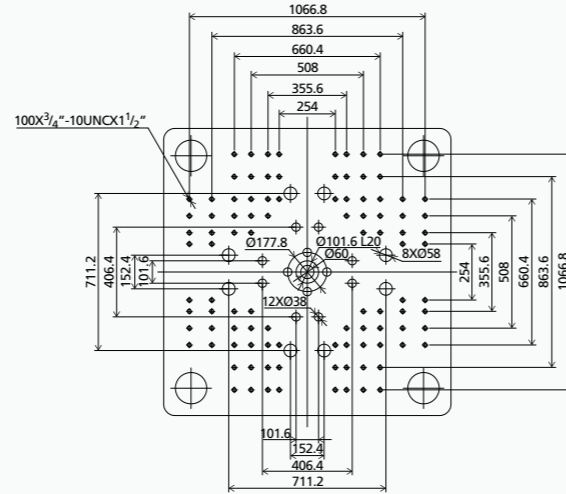

AMERICAN VERSION FIXED PLATEN

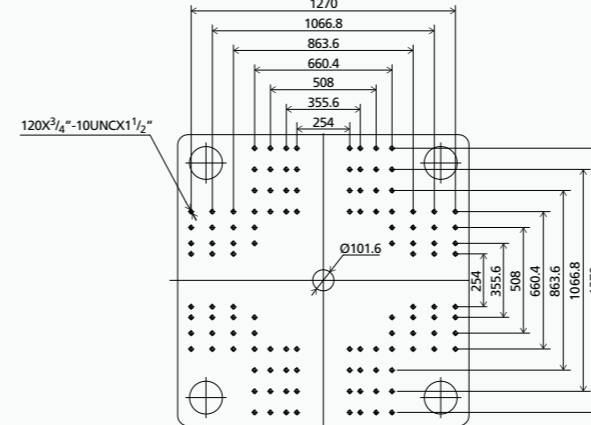

MOVABLE PLATEN

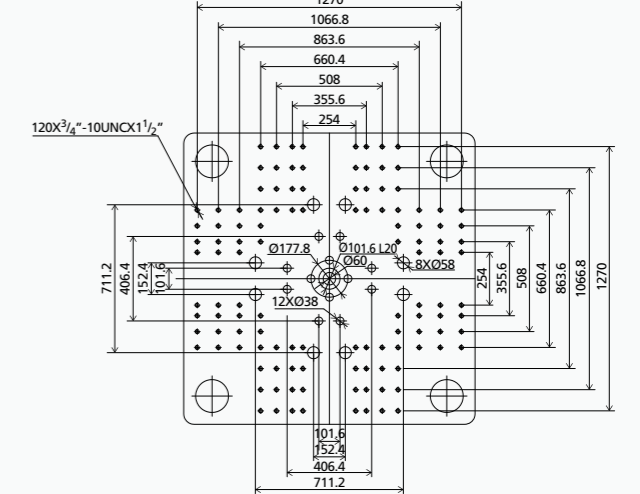

JAPANESE VERSION FIXED PLATEN

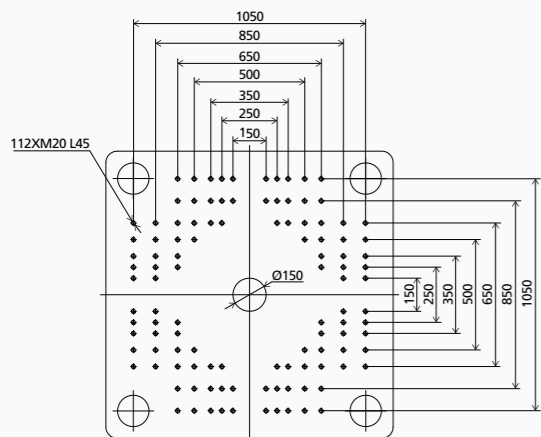

MOVABLE PLATEN

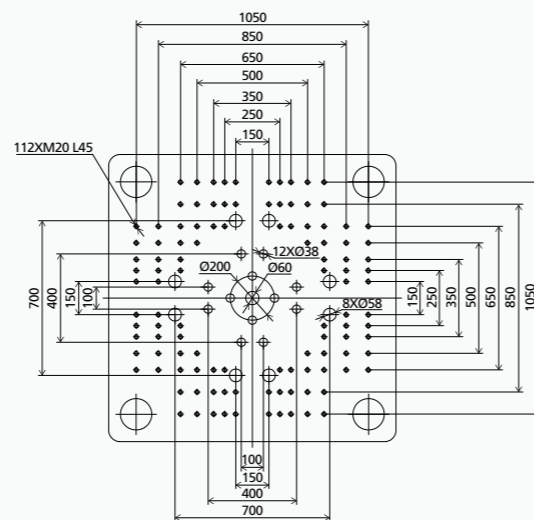

JAPANESE VERSION FIXED PLATEN

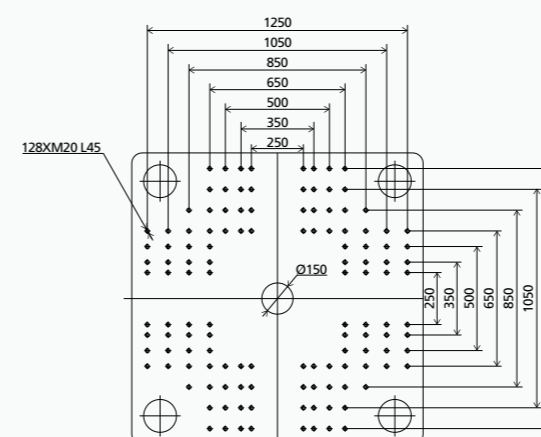

MOVABLE PLATEN

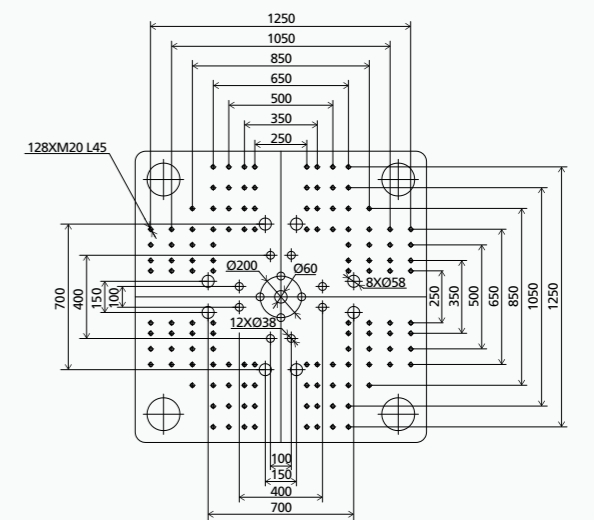

We reserve the right to make changes as a result of further technical advances.

PLATEN LAYOUT ZE6500 III

PLATEN LAYOUT ZE8000 III

EUROPEAN VERSION
FIXED PLATEN

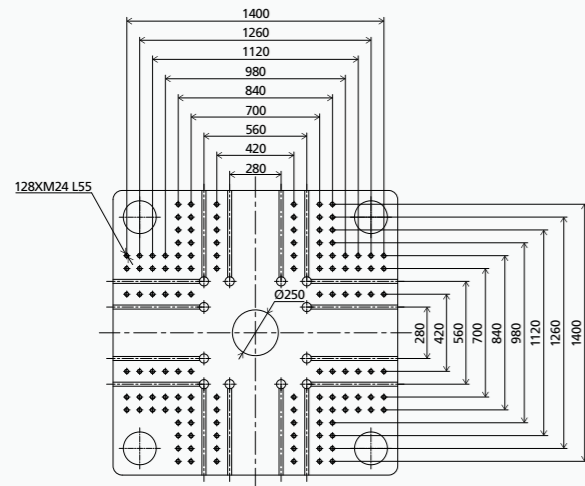

MOVABLE PLATEN

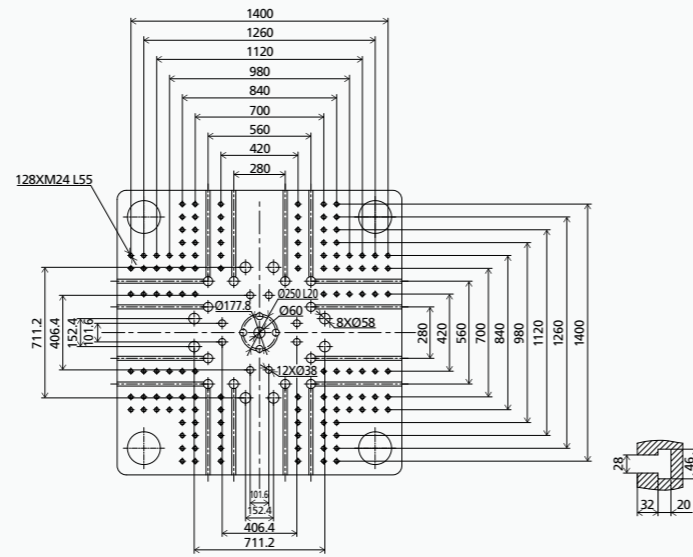

EUROPEAN VERSION
FIXED PLATEN

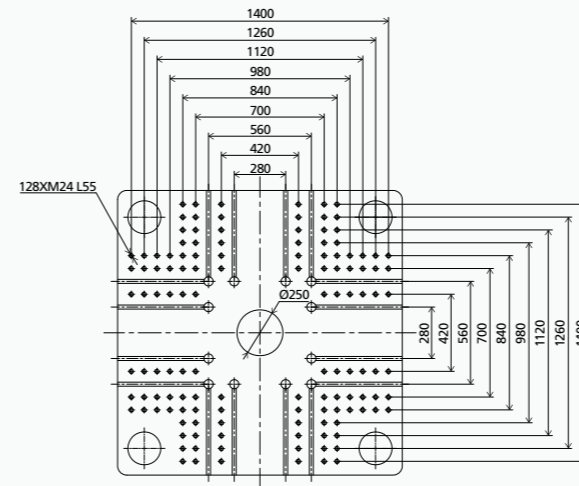

MOVABLE PLATEN

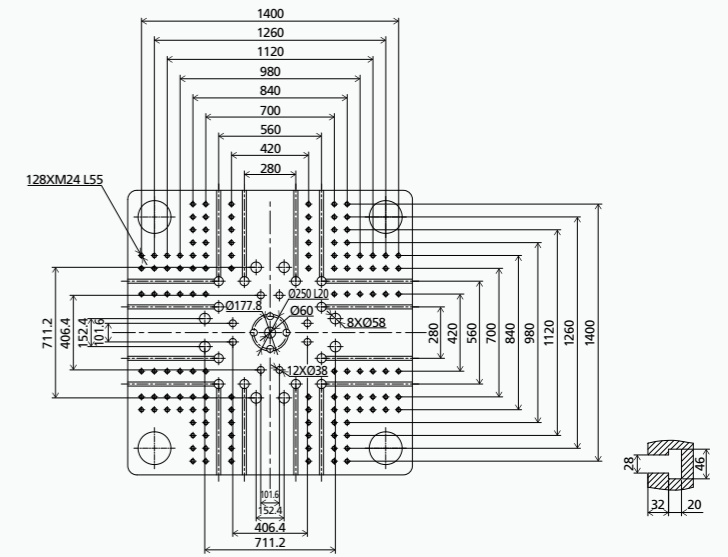

AMERICAN VERSION
FIXED PLATEN

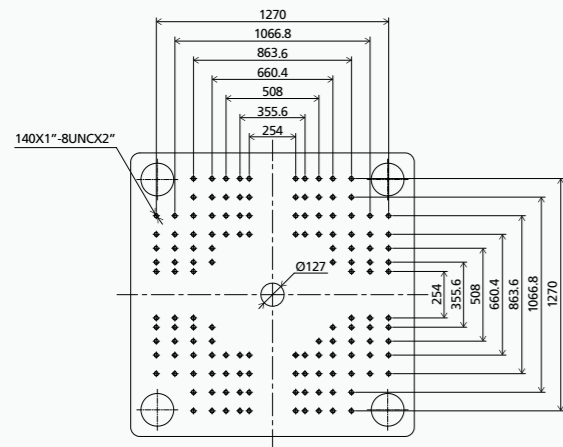

MOVABLE PLATEN

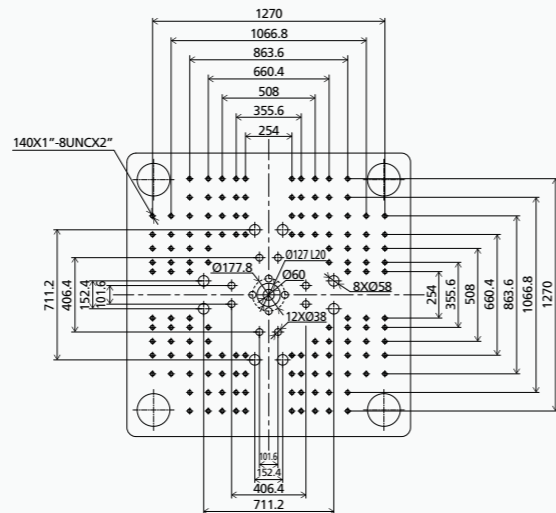

AMERICAN VERSION
FIXED PLATEN

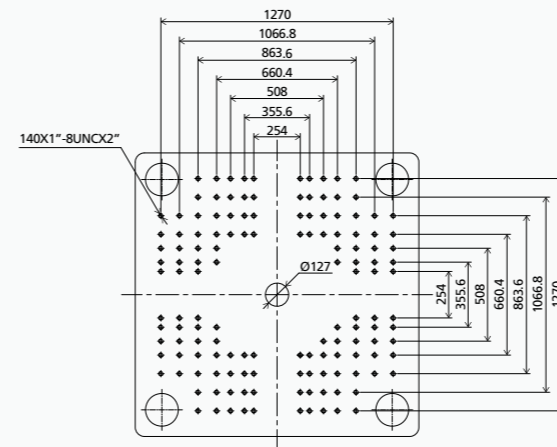

MOVABLE PLATEN

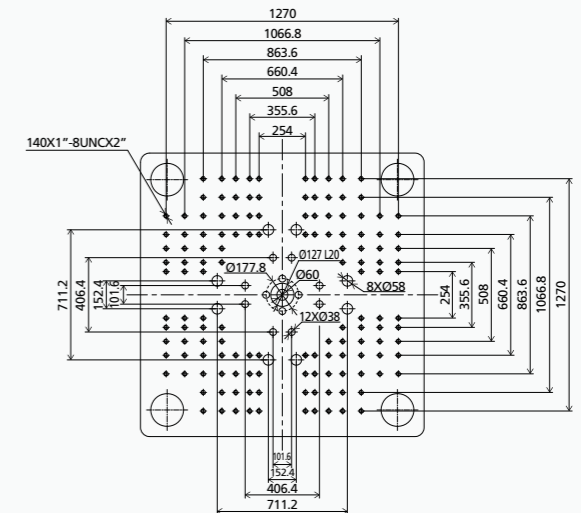

JAPANESE VERSION
FIXED PLATEN

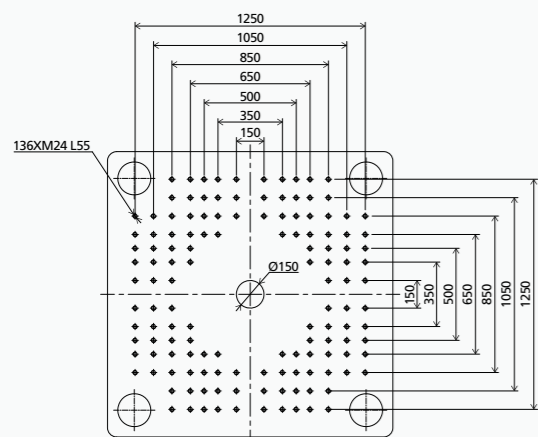

MOVABLE PLATEN

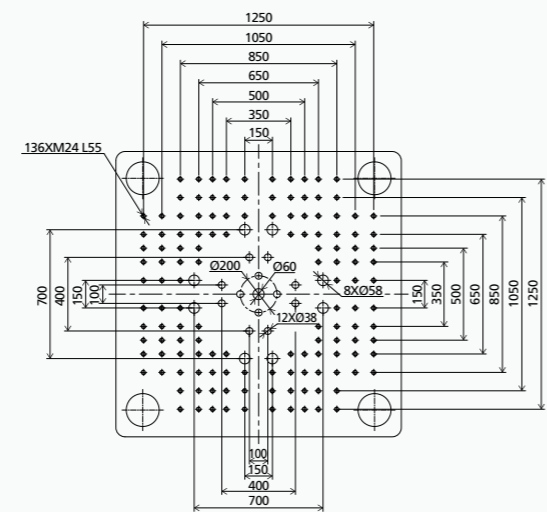

JAPANESE VERSION
FIXED PLATEN

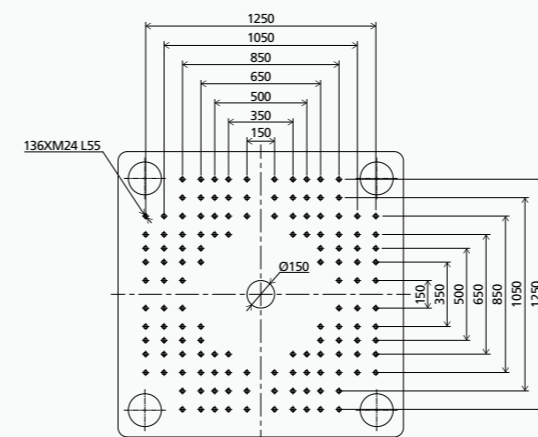

MOVABLE PLATEN

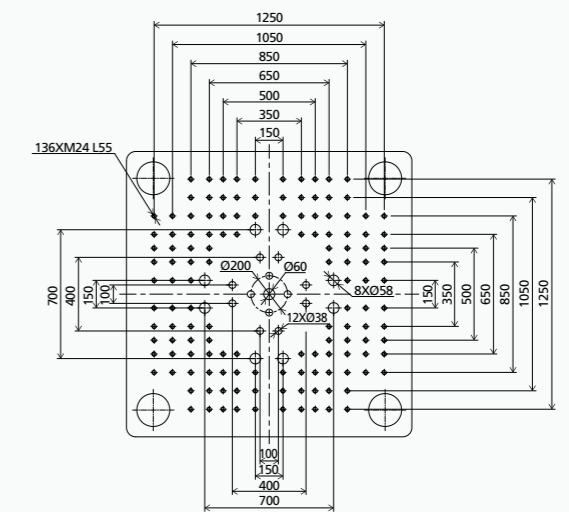

We reserve the right to make changes as a result of further technical advances.

PLATEN LAYOUT ZE9000 III

PLATEN LAYOUT ZE10800 III

EUROPEAN VERSION FIXED PLATEN

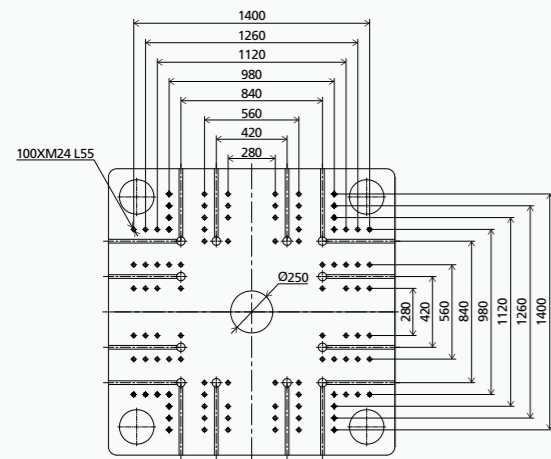

MOVABLE PLATEN

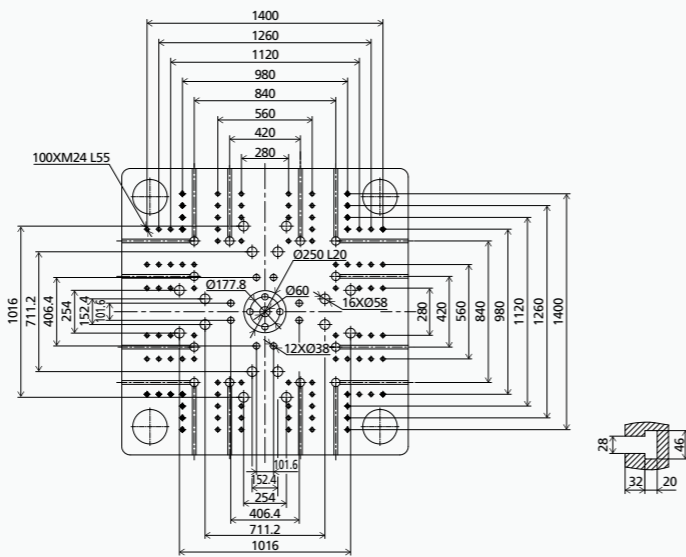

EUROPEAN VERSION FIXED PLATEN

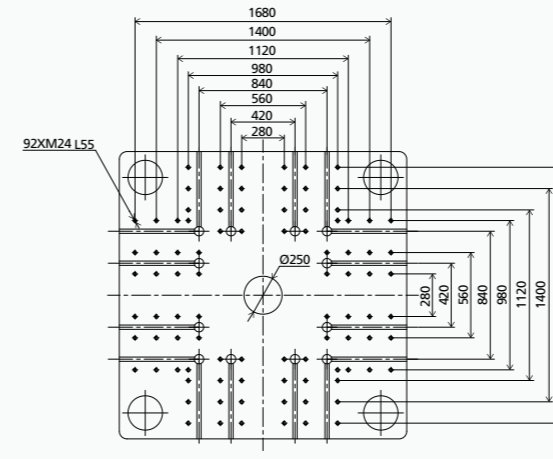

MOVABLE PLATEN

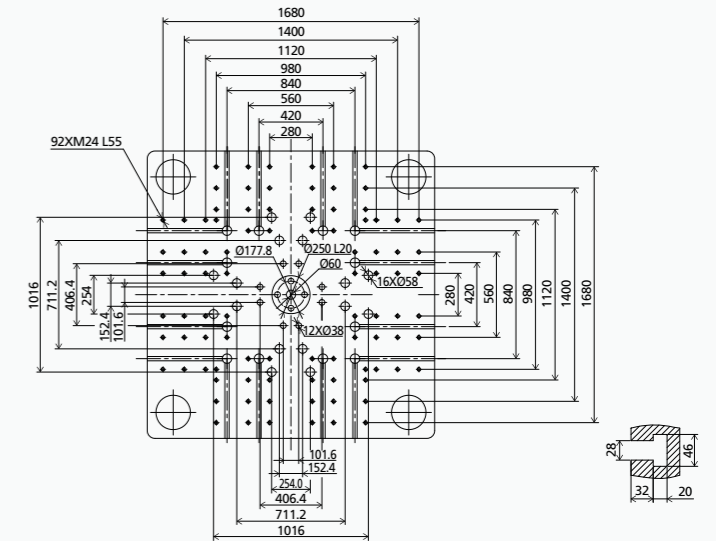

AMERICAN VERSION FIXED PLATEN

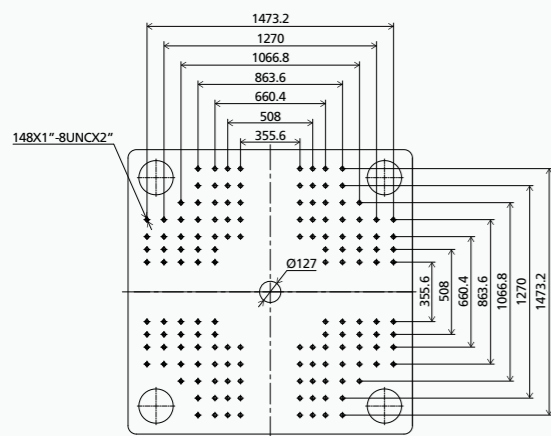

MOVABLE PLATEN

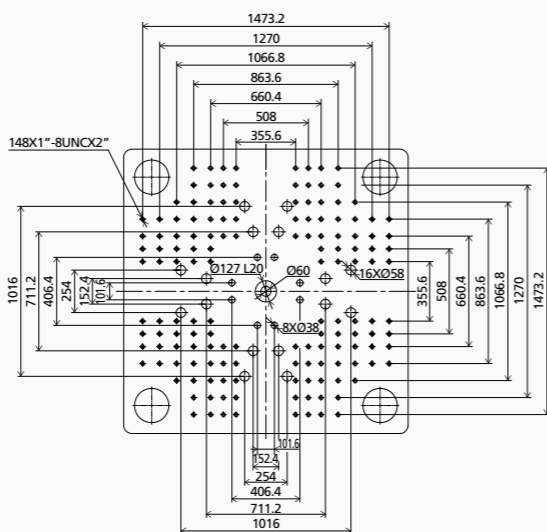

AMERICAN VERSION FIXED PLATEN

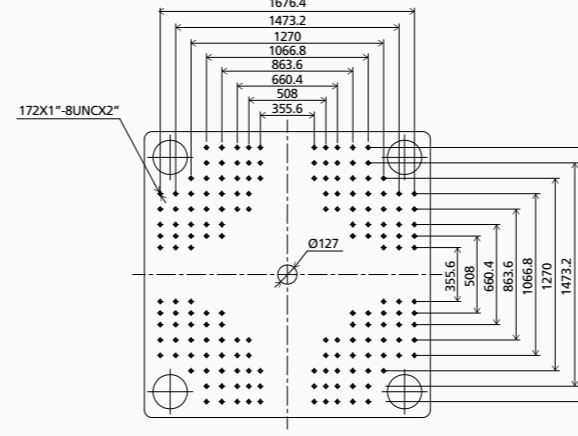

MOVABLE PLATEN

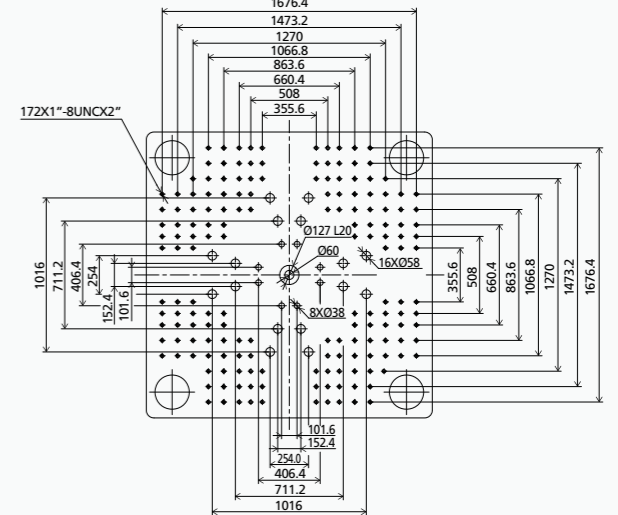

JAPANESE VERSION FIXED PLATEN

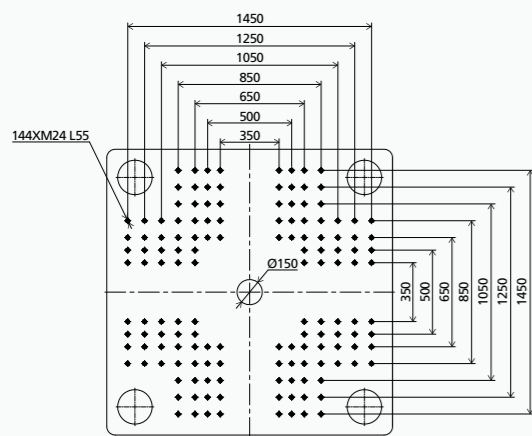

MOVABLE PLATEN

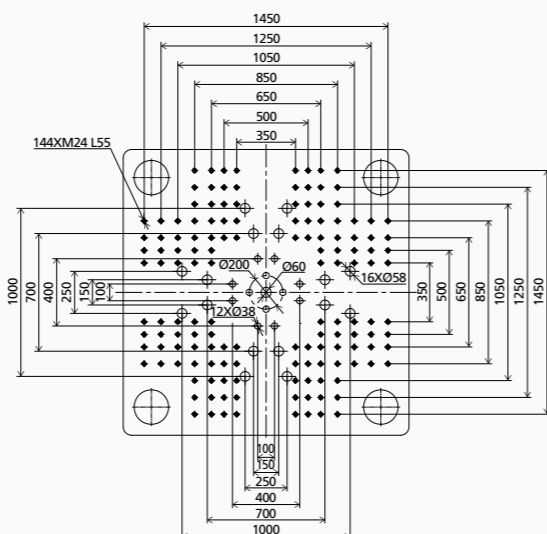

JAPANESE VERSION FIXED PLATEN

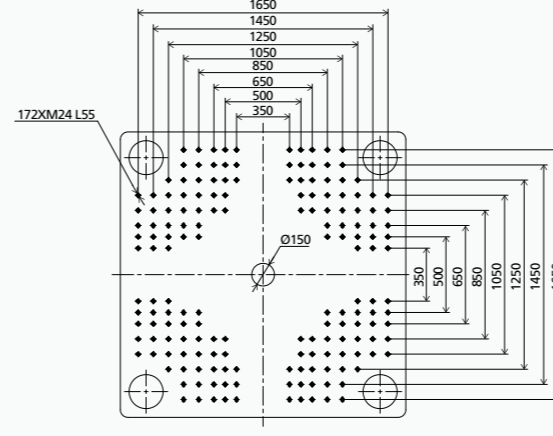

MOVABLE PLATEN

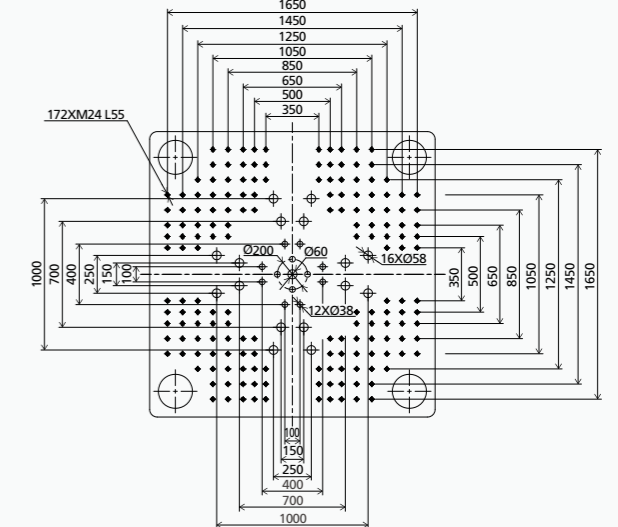

We reserve the right to make changes as a result of further technical advances.

PLATEN LAYOUT ZE13800 III

EUROPEAN VERSION FIXED PLATEN

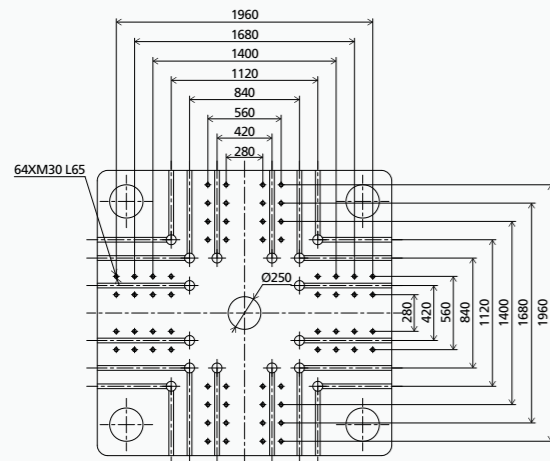

MOVABLE PLATEN

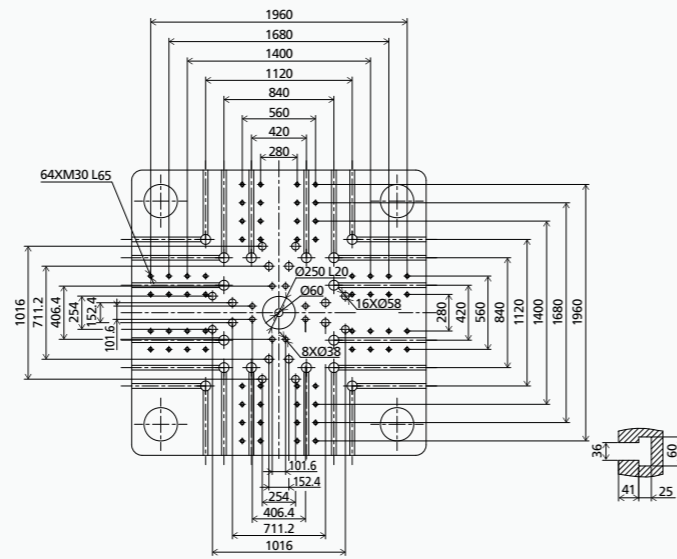

AMERICAN VERSION FIXED PLATEN

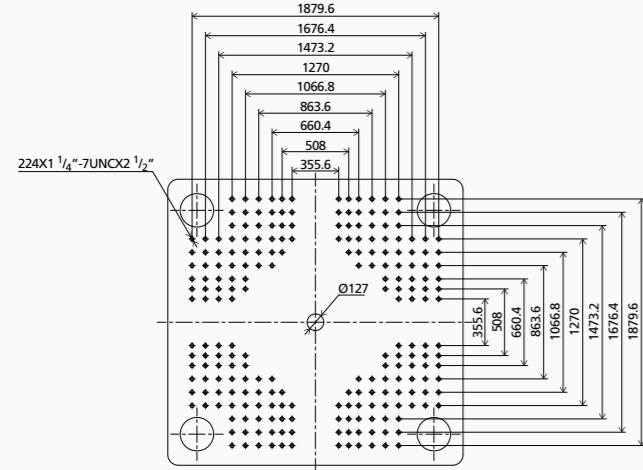

MOVABLE PLATEN

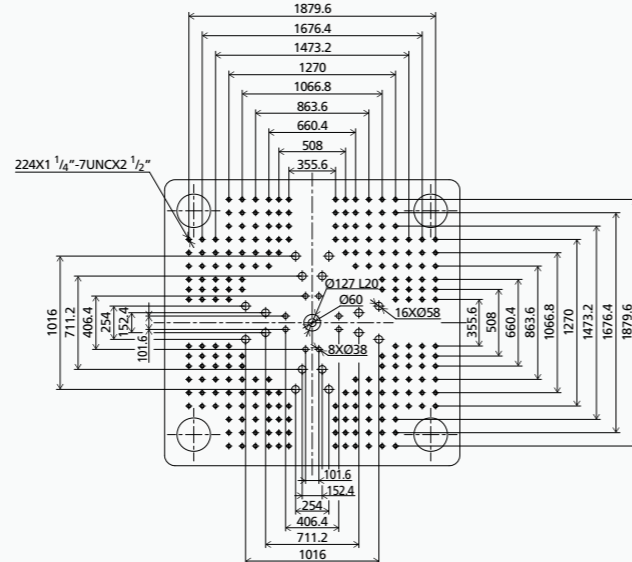

JAPANESE VERSION FIXED PLATEN

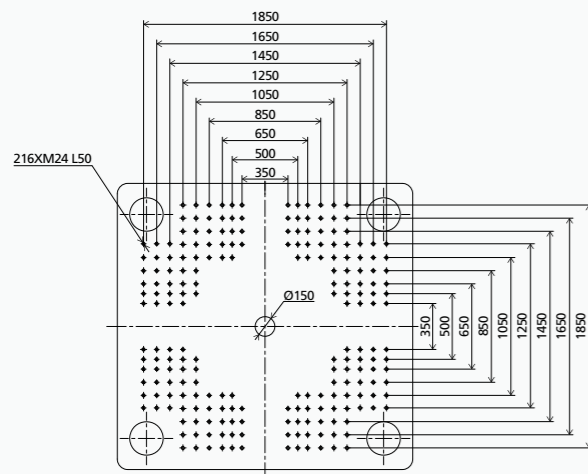

MOVABLE PLATEN

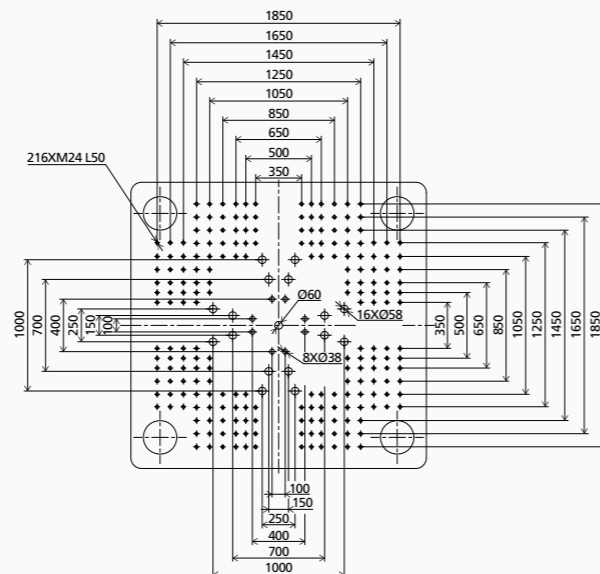

STANDARD EQUIPMENT LIST

GENERAL EQUIPMENT

- » Basic safety device according to GB/22530-2010.
- » ZHAFIR colors: RAL9010, RAL5003
- » Power supply: 380VAC, 3PH+N+PE
- » Sigmatek controller, 15.1 inch touch screen
- » Injection, dosing and platen movement driven independently by servo motor, optical encoder position detection.
- » LUBE central lubrication system
- » Integrated servo hydraulic pack for ejection and carriage movement.

INJECTION UNIT

- » Abrasion-resistant screw set, general version
- » Open nozzle
- » Barrel heating temperature PID control, SSR
- » Extended nozzle, temperature PID control independently
- » Feeding zone temperature closed-loop control
- » Injection speed 6 steps
- » Speed responding mode adjustable
- » Holding pressure 4 steps
- » Pressure responding mode adjustable
- » V/P switch over methods by position/ time/ pressure combinations
- » Dosing rotation speed 3 steps
- » Back pressure 3 steps
- » HPM over-filling protection function
- » Screw retraction before and/or after dosing
- » Auto purge
- » Nozzle sealing force programmable control
- » Swiveling injection unit

CLAMPING UNIT

- » 5-point twin toggle mechanism
- » Center pressing platen
- » Clamping force settable at control panel
- » Automatic mold-height adjustment
- » Platen moving speed 6 steps
- » AI mold protection
- » Clamping force pre-release
- » Ejector speed 3 steps
- » Ejector pressure 3 steps
- » Multi ejection function
- » Ejection parallel to mold opening

FUNCTIONS & CONTROLS

- » Multi-language available (Chinese, German, English, Japanese etc.)
- » Metric/Imperial unit selectable
- » Dosing parallel to mold opening
- » Injection compression
- » Production assistant device function
- » Maintenance alert
- » 5000 cycles process data recording
- » Amendment report
- » Alarm record
- » Quality control function
- » Mold profile data memory (up to 200 sets)
- » 3 USB interface
- » USB printer interface
- » Injection speed & pressure curve
- » 1 free programmable I/O
- » Mold ejector protection interface
- » EUROMAP 12 interface for handling device
- » Auxiliary socket 3PH/380V 32A×1, 16A×2
- » 3 color alarm lamp (red/yellow/green)

OTHERS

- » Tool kit & spare parts package
- » Leveling pads
- » Documents with machine
- » Operating manual